

Deewave Electronics offers a line of SMA/N Coaxial Isolators in various package sizes and frequency bands, specifically designed for cellular and wireless markets. Reliability, cost and manufacturability are optimized at the design stage. Coaxial Isolators are designed to have some RFI and magnetic shielding with high quality materials to ensure optimum performance over the temperature range.

Coaxial Isolators with RF connectors, phase matching, counter clockwise rotation, higher reverse power capability, higher shielding along with required intermodulation specifications can be provided upon request. Deewave Electronics provide coaxial isolators with commercial series, broadbands series, high isolation series and etc.

And also, Deewave Electronics has the ability to provide a wide range of solutions to meet most applications.

## Commercial Series

Part Number	Frequency Range (GHz)	Insertion Loss (dB Max)	Isolation (dB Min)	VSWR (Max)	Operating Temperature (°C)	Forward Power (W)	Reverse Power (W)	Connector type	Package Code
DCI045047-1	0.450-0.470	0.30	23	1.20	-40~+85	150	10	SMAF	A08
DCI045047-2	0.450-0.470	0.30	23	1.20	-40~+85	150	10	SMAF	A09
DCI069080-1	0.698-0.806	0.40	20	1.25	-40~+85	150	10	SMAF	A08
DCI069080-2	0.698-0.806	0.40	20	1.25	-40~+85	150	10	SMAF	A09
DCI082084-1	0.824-0.849	0.30	25	1.20	-40~+85	100	10	SMAF	A01
DCI082084-2	0.824-0.849	0.30	25	1.20	-40~+85	100	10	SMAF	A02
DCI082084-3	0.824-0.849	0.30	25	1.20	-40~+85	150	100	SMAF	A03
DCI086089-1	0.869-0.894	0.30	25	1.20	-40~+85	100	10	SMAF	A01
DCI086089-2	0.869-0.894	0.30	25	1.20	-40~+85	100	10	SMAF	A02
DCI086089-3	0.869-0.894	0.30	25	1.20	-40~+85	150	100	SMAF	A03
DCI089091-1	0.890-0.915	0.30	25	1.20	-40~+85	100	10	SMAF	A01
DCI089091-2	0.890-0.915	0.30	25	1.20	-40~+85	100	10	SMAF	A02
DCI089091-3	0.890-0.915	0.30	25	1.20	-40~+85	150	100	SMAF	A03
DCI093096-1	0.935-0.960	0.30	25	1.20	-40~+85	100	10	SMAF	A01
DCI093096-2	0.935-0.960	0.30	25	1.20	-40~+85	100	10	SMAF	A02
DCI093096-3	0.935-0.960	0.30	25	1.20	-40~+85	150	100	SMAF	A03
DCI171178-1	1.710-1.785	0.30	25	1.20	-40~+85	100	10	SMAF	A04
DCI171178-2	1.710-1.785	0.30	25	1.20	-40~+85	100	10	SMAF	A05
DCI171178-3	1.710-1.785	0.30	25	1.20	-40~+85	150	100	SMAF	A06
DCI175178-1	1.755-1.785	0.30	25	1.20	-40~+85	100	10	SMAF	A04

Note: All the specs above are at room temperature.

## Commercial Series

Part Number	Frequency Range (GHz)	Insertion Loss (dB Max)	Isolation (dB Min)	VSWR (Max)	Operating Temperature (°C)	Forward Power (W)	Reverse Power (W)	Connector type	Package Code
DCI175178-2	1.755-1.785	0.30	25	1.20	-40~+85	100	10	SMAF	A05
DCI175178-3	1.755-1.785	0.30	25	1.20	-40~+85	150	100	SMAF	A06
DCI180188-1	1.805-1.880	0.30	25	1.20	-40~+85	100	10	SMAF	A04
DCI180188-2	1.805-1.880	0.30	25	1.20	-40~+85	100	10	SMAF	A05
DCI180188-3	1.805-1.880	0.30	25	1.20	-40~+85	150	100	SMAF	A06
DCI185188-1	1.850-1.880	0.30	25	1.20	-40~+85	100	10	SMAF	A04
DCI185188-2	1.850-1.880	0.30	25	1.20	-40~+85	100	10	SMAF	A05
DCI185188-3	1.850-1.880	0.30	25	1.20	-40~+85	150	100	SMAF	A06
DCI185191-1	1.850-1.910	0.30	25	1.20	-40~+85	100	10	SMAF	A04
DCI185191-2	1.850-1.910	0.30	25	1.20	-40~+85	100	10	SMAF	A05
DCI185191-3	1.850-1.910	0.30	25	1.20	-40~+85	150	100	SMAF	A06
DCI188192-1	1.880-1.920	0.30	25	1.20	-40~+85	100	10	SMAF	A04
DCI188192-2	1.880-1.920	0.30	25	1.20	-40~+85	100	10	SMAF	A05
DCI188192-3	1.880-1.920	0.30	25	1.20	-40~+85	150	100	SMAF	A06
DCI192198-1	1.920-1.980	0.30	25	1.20	-40~+85	100	10	SMAF	A04
DCI192198-2	1.920-1.980	0.30	25	1.20	-40~+85	100	10	SMAF	A05
DCI192198-3	1.920-1.980	0.30	25	1.20	-40~+85	150	100	SMAF	A06
DCI193199-1	1.930-1.990	0.30	25	1.20	-40~+85	100	10	SMAF	A04
DCI193199-2	1.930-1.990	0.30	25	1.20	-40~+85	100	10	SMAF	A05
DCI193199-3	1.930-1.990	0.30	25	1.20	-40~+85	150	100	SMAF	A06
DCI201202-1	2.010-2.025	0.30	25	1.20	-40~+85	100	10	SMAF	A04
DCI201202-2	2.010-2.025	0.30	25	1.20	-40~+85	100	10	SMAF	A05
DCI201202-3	2.010-2.025	0.30	25	1.20	-40~+85	150	100	SMAF	A06
DCI211217-1	2.110-2.170	0.30	25	1.20	-40~+85	100	10	SMAF	A04
DCI211217-2	2.110-2.170	0.30	25	1.20	-40~+85	100	10	SMAF	A05
DCI211217-3	2.110-2.170	0.30	25	1.20	-40~+85	150	100	SMAF	A06
DCI230240-1	2.300-2.400	0.30	23	1.20	-40~+85	100	10	SMAF	A04
DCI230240-2	2.300-2.400	0.30	23	1.20	-40~+85	100	10	SMAF	A05
DCI230240-3	2.300-2.400	0.30	23	1.20	-40~+85	150	100	SMAF	A06
DCI340360	3.400-3.600	0.30	23	1.20	-40~+85	30	5	SMAF	A07
DCI8701040	8.70-10.40	0.40	23	1.20	-40~+85	10	5	SMAF	A10
DCI10101070	10.10-10.70	0.30	23	1.20	-40~+85	10	5	SMAF	A10
DCI11001200	11.00-12.00	0.40	23	1.20	-40~+85	10	5	SMAF	A10
DCI12751325	12.75-13.25	0.30	23	1.20	-40~+85	10	5	SMAF	A10
DCI14251535	14.25-15.35	0.40	20	1.25	-40~+85	10	5	SMAF	A10
DCI16801800	16.80-18.00	0.50	20	1.30	-40~+85	10	5	SMAF	A10
DCI17701970	17.70-19.70	0.50	20	1.30	-40~+85	10	5	SMAF	A10
DCI23502450	23.50-24.50	0.60	20	1.30	-40~+85	10	5	SMAF	A11

Note: All the specs above are at room temperature.

## Broadbands Series

Part Number	Frequency Range (GHz)	Insertion Loss (dB Max)	Isolation (dB Min)	VSWR (Max)	Operating Temperature (°C)	Reverse Power (W)	Connector type	Package Code
DCI100200B	1-2	0.70	16	1.40	0~+60	10	SMAF	A12
DCI135270B	1.35-2.7	0.60	17	1.35	0~+60	10	SMAF	A13
DCI150250B	1.5-2.5	0.70	17	1.30	-30~+70	10	SMAF	A14
DCI200400B	2-4	0.60	18	1.40	-30~+70	10	SMAF	A15
DCI200600B	2-6	1.20	15	1.50	0~+60	10	SMAF	A16
DCI200800B	2-8	1.50	12	1.80	0~+60	10	SMAF	A16
DCI300600B	3-6	0.60	17	1.40	-30~+70	10	SMAF	A17
DCI350700B	3.5-7	0.60	17	1.40	-30~+70	10	SMAF	A18
DCI400800B	4-8	0.60	18	1.30	-30~+70	5	SMAF	A19
DCI5001000B	5-10	0.60	18	1.30	-30~+70	5	SMAF	A19
DCI6001200B	6-12	0.60	18	1.40	-30~+70	5	SMAF	A20
DCI6001800B	6-18	1.50	12	1.80	-30~+70	5	SMAF	A21
DCI8001200B	8-12	0.50	20	1.25	-30~+70	5	SMAF	A22
DCI8001800B	8-18	0.80	17	1.40	-30~+70	5	SMAF	A23
DCI10001500B	10-15	0.50	20	1.25	-30~+70	5	SMAF	A22
DCI12001800B	12-18	0.60	20	1.30	-30~+70	5	SMAF	A22

## High Isolation Series (Dual-junction Coaxial Isolator)

Part Number	Frequency Range (GHz)	Insertion Loss (dB Max)	Isolation (dB Min)	VSWR (Max)	Operating Temperature (°C)	Forward Power (W)	Reverse Power (W)	Connector type	Package Code
DCI086089I	0.869-0.894	0.60	50	1.20	-40~+85	150	10	SMAF	A24
DCI093096I	0.935-0.960	0.60	50	1.20	-40~+85	150	10	SMAF	A24
DCI180188I	1.805-1.880	0.60	50	1.20	-40~+85	150	10	SMAF	A25
DCI193199I	1.930-1.990	0.60	50	1.20	-40~+85	150	10	SMAF	A25
DCI211217I	2.110-2.170	0.60	50	1.20	-40~+85	150	10	SMAF	A25

## Select-A-Frequency (Customerized)

Part Number	Frequency Range (GHz)	Band Width (MHz)	Insertion Loss (dB Max)	Isolation (dB Min)	VSWR (Max)	Operating Temperature (°C)	Reverse Power (W)	Size L*W*H (mm)	Connector type
DCI015020C	0.15-0.2	8	0.60	16	1.40	0~+60	10	70*70*22	SMA/N
DCI015020C	0.15-0.2	8	0.60	16	1.40	0~+60	100	70*97*22	SMA/N
DCI020025C	0.2-0.25	20	0.50	18	1.30	0~+60	10	50.5*53*22	SMA/N
		20	0.50	18	1.30	0~+60	100	50.5*80*22	SMA/N
DCI030040C	0.3-0.4	30	0.30	25	1.20	-15~+60	10	52*57.5*22	SMA/N
		30	0.30	25	1.20	-15~+60	100	52*84.5*22	SMA/N
DCI030050C	0.3-0.5	30	0.50	50	1.20	-15~+60	100	104*57.5*22	SMA/N

Note: All the specs above are at room temperature.

## Select-A-Frequency (Customerized)

Part Number	Frequency Range (GHz)	Band Width (MHz)	Insertion Loss (dB Max)	Isolation (dB Min)	VSWR (Max)	Operating Temperature (°C)	Reverse Power (W)	Size L*W*H (mm)	Connector type
DCI040060C	0.4-0.6	30	0.30	25	1.20	-15~+60	10	44*49.5*21	SMA/N
		30	0.30	25	1.20	-15~+60	100	44*76.5*21	SMA/N
		10	0.30	25	1.20	-15~+60	10	35*38*20	SMA/N
		10	0.30	25	1.20	-15~+60	10	38.1*38.1*15	SMA
DCI060100C	0.6-1.0	30	0.30	25	1.20	-30~+70	10	35*38*20	SMA/N
		200	0.40	20	1.25	-30~+70	10		
		30	0.30	25	1.20	-30~+70	10	38.1*38.1*15	SMA
		200	0.40	20	1.25	-30~+70	10		
DCI080120C	0.8-1.2	70	0.30	25	1.20	-30~+70	10	30*33*20	SMA/N
		200	0.40	20	1.25	-30~+70	10		
		70	0.30	25	1.20	-30~+70	100	30*43*20	SMA/N
		200	0.40	20	1.25	-30~+70	100		
		70	0.30	25	1.20	-30~+70	10	30*33*15	SMA
		200	0.40	20	1.25	-30~+70	10		
		70	0.60	50	1.20	-30~+70	100	60*33*20	SMA/N
DCI120270C	1.2-2.7	70	0.30	25	1.20	-30~+70	10	25.4*28.5*20	SMA/N
		200	0.40	20	1.25	-30~+70	10		
		70	0.30	25	1.20	-30~+70	100	25.4*38.5*20	SMA/N
		200	0.40	20	1.25	-30~+70	100		
		70	0.30	25	1.20	-30~+70	10	25.4*28.5*15	SMA
		200	0.40	20	1.25	-30~+70	10		
		70	0.60	50	1.20	-30~+70	10	50.8*28.5*20	SMA/N
		200	0.80	40	1.25	-30~+70	10		
DCI150250C	1.5-2.5	70	0.30	25	1.20	-30~+70	10	20*25.4*15	SMA
DCI180350C	1.8-3.5	200	0.30	25	1.20	-30~+70	10	25*25*15	SMA
		400	0.40	20	1.20	-30~+70	10		
DCI350650C	3.5-6.5	300	0.30	25	1.20	-40~+75	10	16*26*15	SMA
		600	0.40	23	1.20	-40~+75	10		
		300	0.30	25	1.20	-40~+75	10	16*26*19	N
		600	0.40	23	1.20	-40~+75	10		
		300	0.60	50	1.20	-40~+75	10	32*26*13	SMA
		600	0.80	45	1.20	-40~+75	10		
		300	0.60	50	1.20	-40~+75	10	32*26*19	N
		600	0.80	45	1.20	-40~+75	10		
DCI7001800C	7.0-18.0	500	0.30	25	1.20	-40~+75	10	12*20*13	SMA
		1000	0.40	23	1.20	-40~+75	10		
		500	0.50	50	1.20	-40~+75	10	24*20*13	SMA

Note: All the specs above are at room temperature.

## Package Drawing

### A01

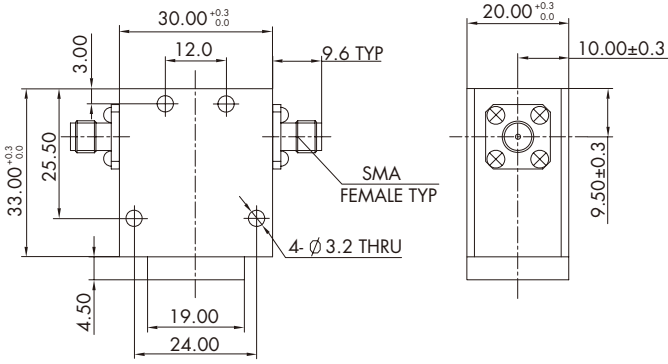

### A02

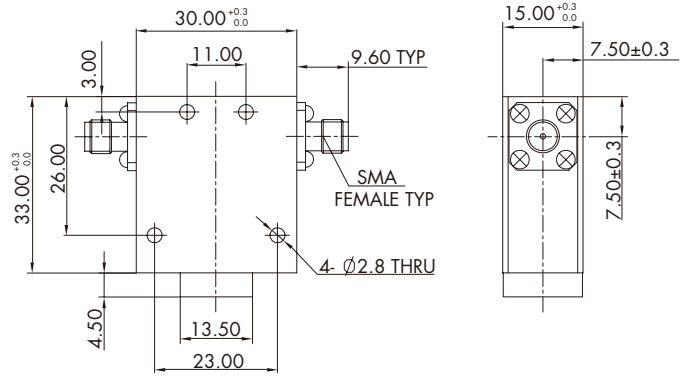

### A03

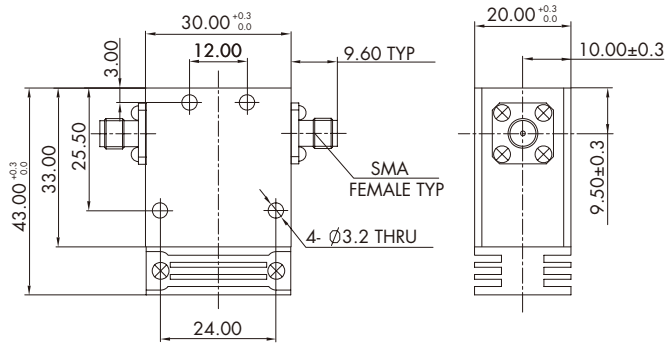

### A04

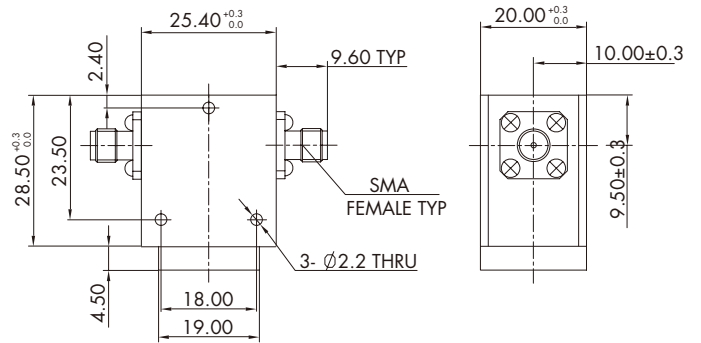

### A05

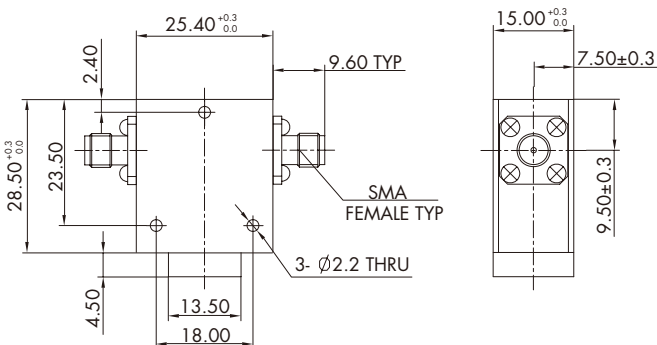

### A06

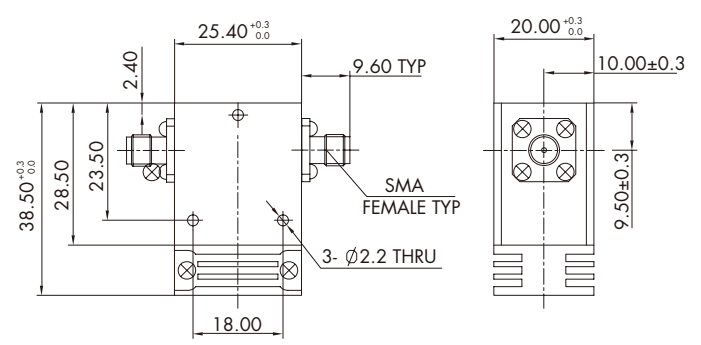

Note: All dimensions are in mm.

## Package Drawing

### A07

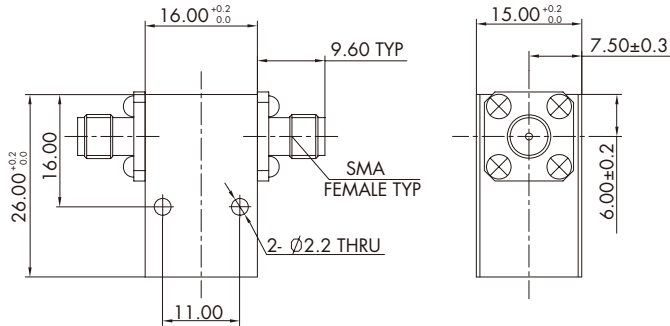

### A08

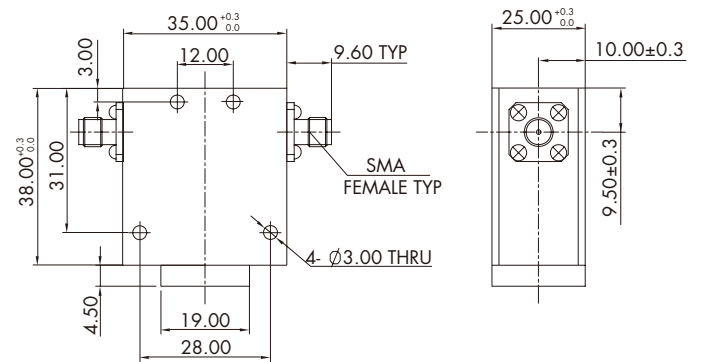

### A09

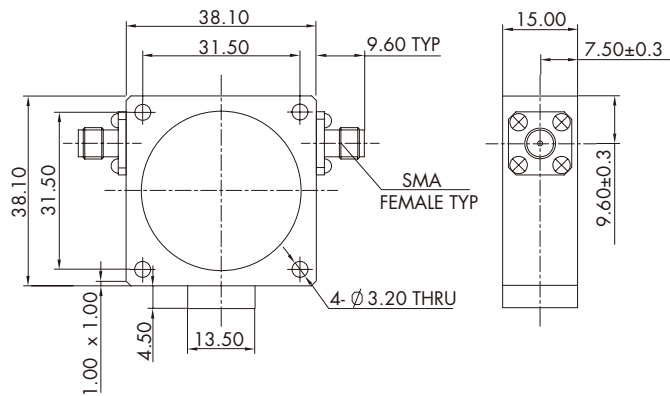

### A10

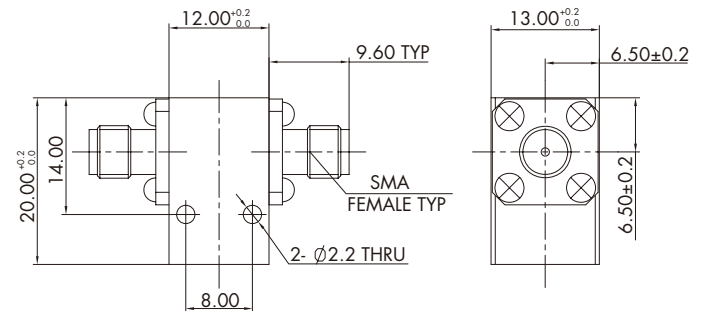

### A11

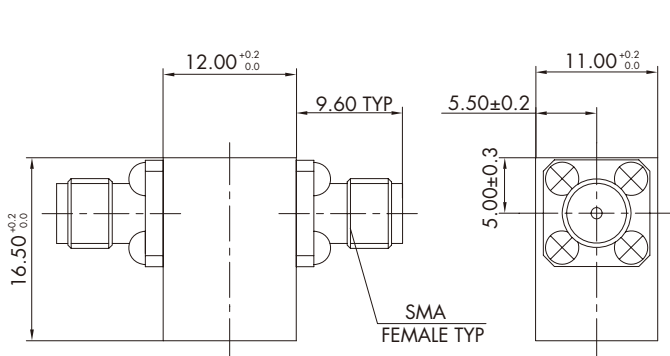

### A12

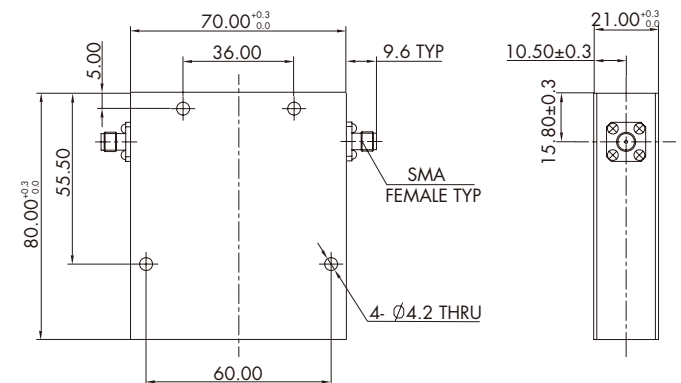

Note: All dimensions are in mm.

## Package Drawing

### A13

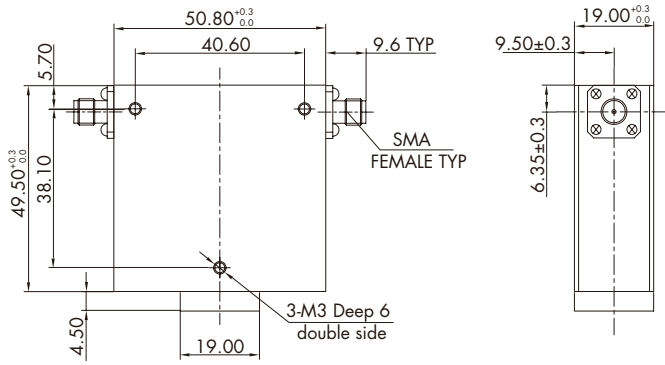

### A14

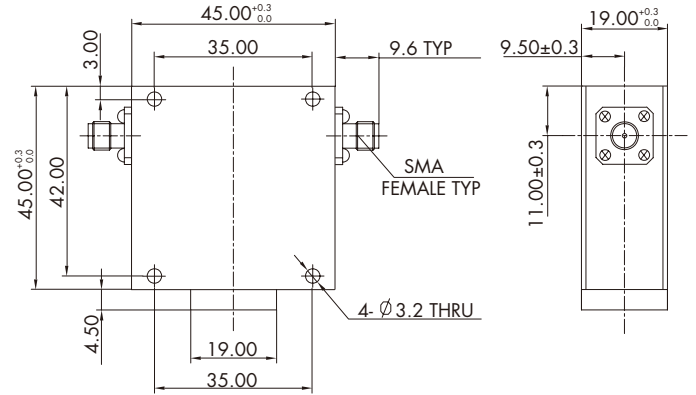

### A15

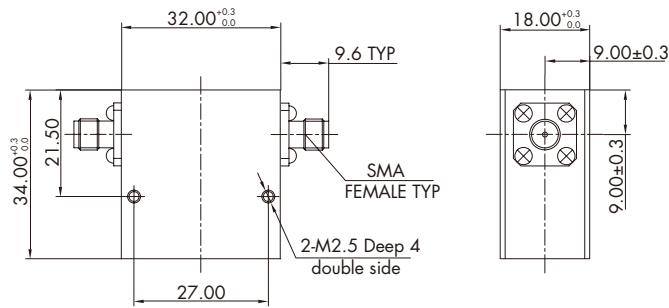

### A16

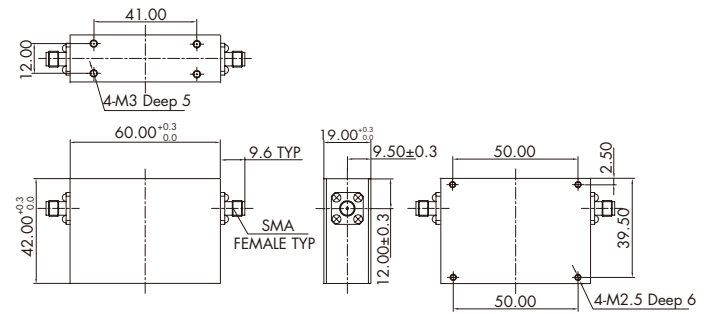

### A17

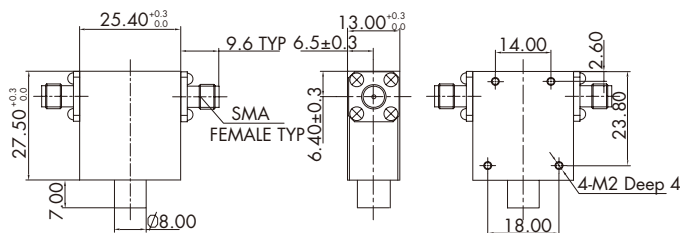

### A18

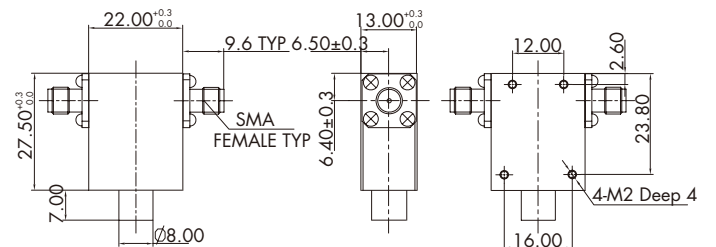

Note: All dimensions are in mm.

## Package Drawing

### A19

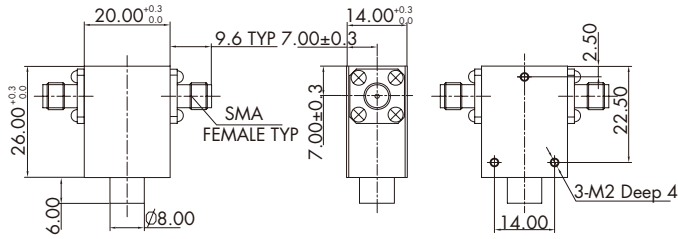

### A20

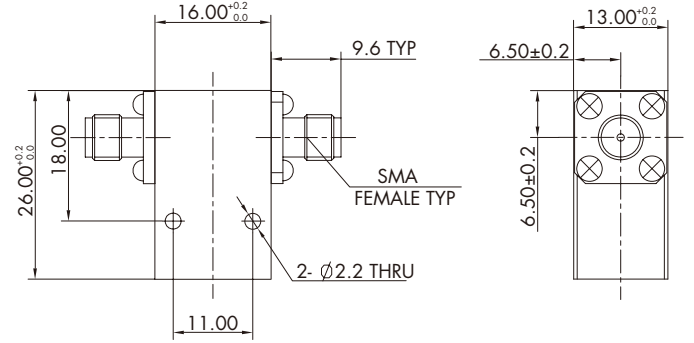

### A21

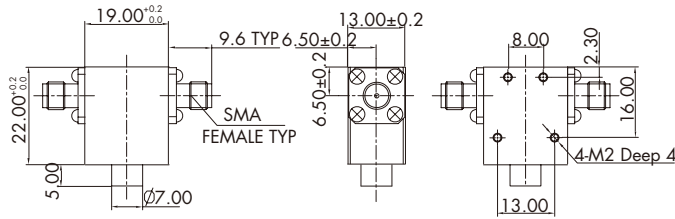

### A22

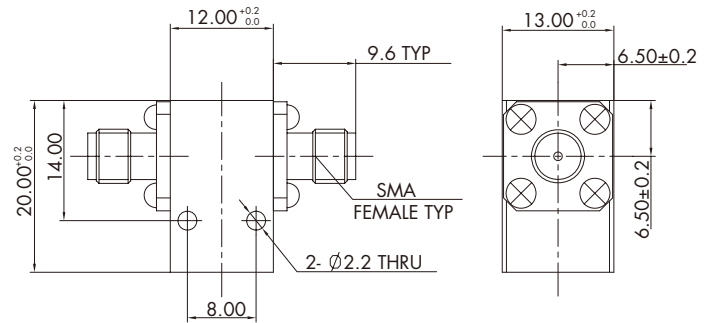

### A23

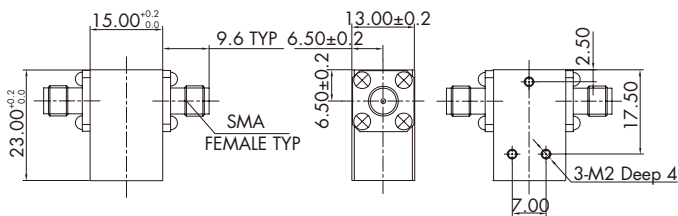

### A24

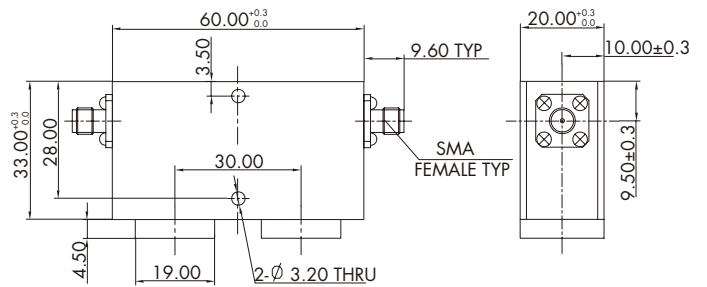

Note: All dimensions are in mm.



